

FANUC Robot M-10

FANUC Robot M-20



FEATURES

FANUC Robot M-10 / M-20 is a cable integrated compact handling robot.

- The unique gear drive mechanism realizes the high inertia and the slim arm of the cable integrated robot.
- The cables and tubes backside the tool control box can be integrated in the enlarged J1 hollow part.
- Various cables and tubes using for hand control can be integrated in the J3 arm due to the enlarged J4 and J6 hollow parts. The tool control box can be compactly mounted backside of the J3 arm.
- Higher rigidity of the arm provides high speed and high accuracy of the robot motion. It can enhance the productivity of the system.
- Off-line teaching by ROBOGUIDE (Option) reduces touch-up cost.
- Various intelligent functions with *i*RVision (integrated robot vision) and the force sensor are available.
- Dustproof wrist cover specification (IP67) suitable for dusty environments is optionally available for M-10/12-14D.
- Food oil specification applied with lubricant for food machinery is optionally available for M-10/12-14D and M-20/25-18D.

Application Examples



Handling of sheet metal parts



FIBER LASER welding

Operating space

M-10

M-20

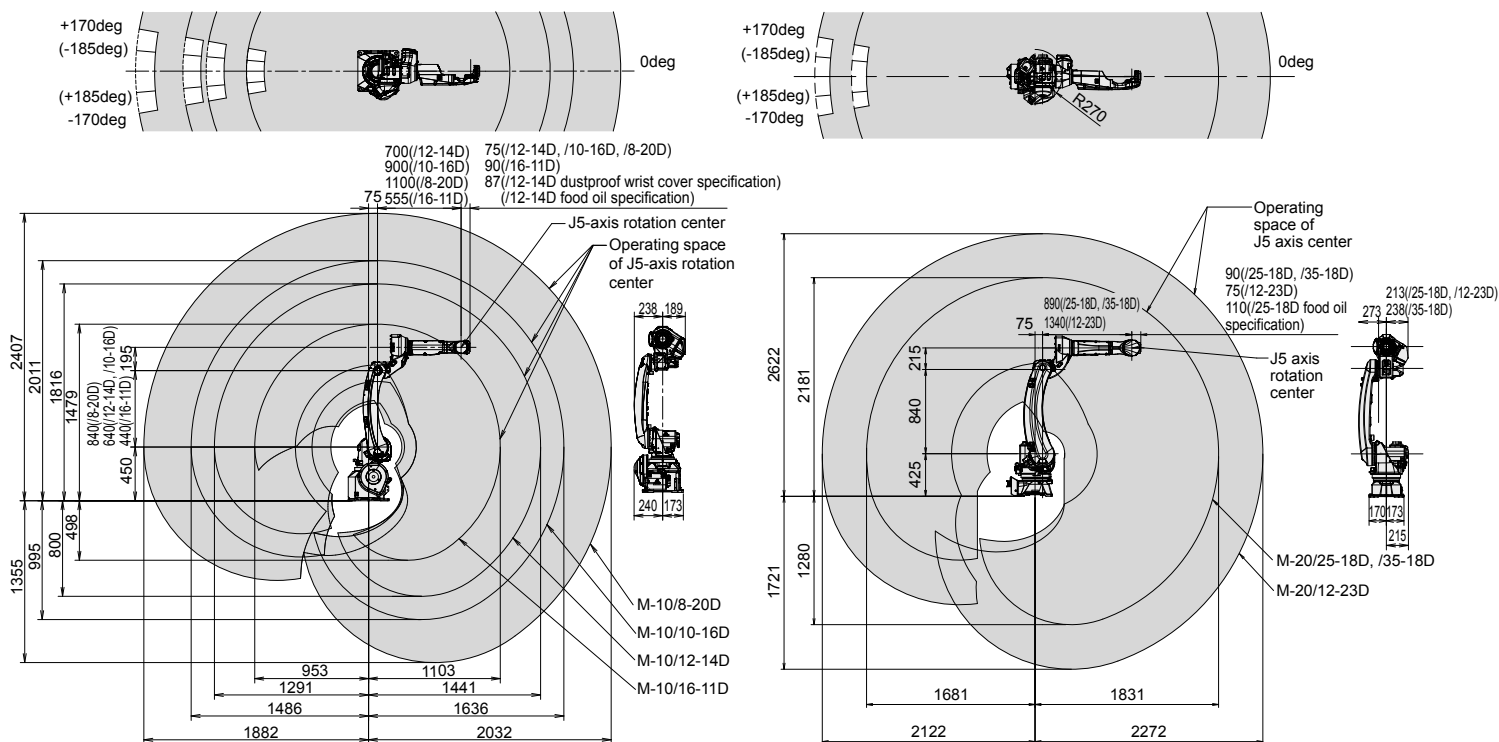

Specifications

Model	M-10/16-11D	M-10/12-14D	M-10/10-16D	M-10/8-20D	M-20/25-18D	M-20/35-18D	M-20/12-23D
Control axes	6 axes (J1, J2, J3, J4, J5, J6)						
Reach	1103 mm	1441 mm	1636 mm	2032 mm	1831 mm		2272 mm
Installation Note 1)	Floor, Upside-down, Angle mount						
Motion range (Maximum speed) Note 2), 3), 4), 5), 6)	J1 axis	370° (290°/s) 6.46 rad (5.06 rad/s)	370° (260°/s) 6.46 rad (4.54 rad/s)	370° (210°/s) 6.46 rad (3.67 rad/s)		370° (180°/s) 6.46 rad (3.14 rad/s)	370° (210°/s) 6.46 rad (3.67 rad/s)
	J2 axis	235° (270°/s) 4.10 rad (4.71 rad/s)	235° (240°/s) 4.10 rad (4.19 rad/s)	235° (210°/s) 4.10 rad (3.67 rad/s)	260° (210°/s) 4.54 rad (3.67 rad/s)	260° (180°/s) 4.54 rad (3.14 rad/s)	260° (210°/s) 4.54 rad (3.67 rad/s)
	J3 axis	455° (270°/s) 7.94 rad (4.71 rad/s)	455° (260°/s) 7.94 rad (4.54 rad/s)	455° (220°/s) 7.94 rad (3.84 rad/s)	458° (265°/s) 8.00 rad (4.63 rad/s)	458° (200°/s) 8.00 rad (3.49 rad/s)	458° (265°/s) 8.00 rad (4.63 rad/s)
	J4 axis		380° (430°/s) 6.63 rad (7.50 rad/s)		400° (420°/s) 6.98 rad (7.33 rad/s)	400° (350°/s) 6.98 rad (6.11 rad/s)	400° (420°/s) 6.98 rad (7.33 rad/s)
	J5 axis		360° (450°/s) 6.28 rad (7.85 rad/s)		360° (420°/s) 6.28 rad (7.33 rad/s)	360° (350°/s) 6.28 rad (6.11 rad/s)	360° (450°/s) 6.28 rad (7.85 rad/s)
	J6 axis	900° (730°/s) 15.71 rad (12.74 rad/s)	900° (720°/s) 15.71 rad (12.57 rad/s)			900° (400°/s) 15.71 rad (6.98 rad/s)	900° (720°/s) 15.71 rad (12.57 rad/s)
Max load capacity at wrist	16 kg	12 kg	10 kg	8 kg	25 kg	35 kg	12 kg
Allowable load moment at wrist	J4 axis	26.0 N·m	22.0 N·m	16.1 N·m	52.0 N·m	110.0 N·m	22.0 N·m
	J5 axis	26.0 N·m	22.0 N·m	16.1 N·m	52.0 N·m	110.0 N·m	22.0 N·m
	J6 axis	11.0 N·m	9.8 N·m	5.9 N·m	32.0 N·m	60.0 N·m	9.8 N·m
Allowable load inertia at wrist	J4 axis	0.90 kg·m ²	0.65 kg·m ²	0.63 kg·m ²	2.40 kg·m ²	4.00 kg·m ²	0.65 kg·m ²
	J5 axis	0.90 kg·m ²	0.65 kg·m ²	0.63 kg·m ²	2.40 kg·m ²	4.00 kg·m ²	0.65 kg·m ²
	J6 axis	0.30 kg·m ²	0.17 kg·m ²	0.061 kg·m ²	1.20 kg·m ²	1.50 kg·m ²	0.17 kg·m ²
Repeatability Note 7)	± 0.02 mm		± 0.03 mm		± 0.03 mm		
Mass Note 8)	145 kg		150 kg	180 kg	250 kg		
Installation environment	Ambient temperature : 0 to 45°C Ambient humidity : Normally 75%RH or less (No condensation allowed), Short term (within one month) 95%RH or less (No condensation allowed) Vibration acceleration : 4.9m/s ² (0.5G) or less						

Note 1) Angle mount is not supported for 4 brake type of M-10/12-14D.

Note 2) In case of equipping mechanical stopper, motion range of J1 axis is restricted to 340° (5.93 rad).

Note 3) In case of angle mounting, J1 and J2 axis motion range are restricted.

Note 4) During short distance motions, the axis speed may not reach the maximum value stated.

Note 5) Motion range of J5 axis is restricted to 240° (4.19 rad) and motion range of J6 axis is restricted to 540° (9.42 rad) for M-10/12-14D with dustproof wrist cover specification.

Note 6) To prevent the interference of the robot main body and the arm, the robot may not reach the upper limit/lower limit of the motion range depending on the posture.

Note 7) Compliant with ISO9283.

Note 8) Without controller.

FANUC CORPORATION

● Overseas Affiliated Companies
 FANUC America Corporation
 FANUC Europe Corporation, S.A.
 SHANGHAI-FANUC Robotics CO., LTD.
 KOREA FANUC CORPORATION
 TAIWAN FANUC CORPORATION
 FANUC INDIA PRIVATE LIMITED
 FANUC SINGAPORE PTE. LTD.
 FANUC THAI LIMITED
 FANUC MECHATRONICS (MALAYSIA) SDN. BHD.
 PT. FANUC INDONESIA
 FANUC OCEANIA PTY. LIMITED
 FANUC SOUTH AFRICA (PROPRIETARY) LIMITED

Phone: (+1)248-377-7000
 Phone: (+352)727777-1
 Phone: (+86)21-5032-7700
 Phone: (+82)55-278-1200
 Phone: (+886)4-2359-0522
 Phone: (+91)80-2852-0057
 Phone: (+65)6567-8566
 Phone: (+66)2-714-6111
 Phone: (+60)3-3082-1222
 Phone: (+62)21-4584-7285
 Phone: (+61)2-8822-4600
 Phone: (+27)11-392-3610

<https://www.fanucamerica.com/>
<https://www.fanuc.eu/>
<https://www.shanghai-fanuc.com.cn/>
<https://www.fkc.co.kr/>
<https://www.fanuctaiwan.com.tw/>
<https://www.fanucindia.com/>
<https://www.fanuc.com/fsp/>
<https://www.fanuc.com/ftth/>
<https://www.fanuc.com/fmm/>
<https://www.fanuc.com/fin/>
<https://www.fanucoceania.com.au/>
<https://fanuc.co.za/>

● Headquarters 3580, Shibokusa, Oshino-mura, Minamitsuru-gun
 Yamanashi, 401-0597, JAPAN
 Phone: (+81)555-84-5555 <https://www.fanuc.co.jp/>

● All specifications are subject to change without notice.
 ● No part of this catalog may be reproduced in any form.
 ● The products in this catalog are controlled based on Japan's 'Foreign Exchange and Foreign Trade Law'. The export from Japan may be subject to an export license by the government of Japan. Further, re-export to another country may be subject to the license of the government of the country from where the product is re-exported. Furthermore, the product may also be controlled by re-export regulations of the United States government. Should you wish to export or re-export these products, please contact FANUC for advice.