

# FANUC Robot M-710



## FEATURES

FANUC Robot M-710 is a middle size handling robot series with the capacity of 12kg - 70kg.

- Six models are available to meet a variety of applications.
  - FANUC Robot M-710/50-26D, /70-21D
    - Wide motion envelop and large wrist load capacity are enough to handle a large panel.
    - Curved arm enables avoiding interference with obstacles in front of the robot and accessing to a deep area more easily.
    - The reduced surface exposure of the joints enhances the dust and liquid resistance.
  - FANUC Robot M-710/12-31C, /20-31C, /20-26C
    - The long reach and high motion performance are suitable for various applications, such as sealing and arc welding.
  - FANUC Robot M-710/50-20C-5X
    - 5 axes type robot suitable for high speed transferring. Upside-down installation is also possible, realizing a compact handling system.
- The full cover realizes high resistance to severe environmental conditions (dust and dips) conform to IP67. It is reliable in various applications, such as load / unload for machined parts, de-burring and die cast loading.

## Application Examples



Handling Cardboard Boxes to Cargo Pallet

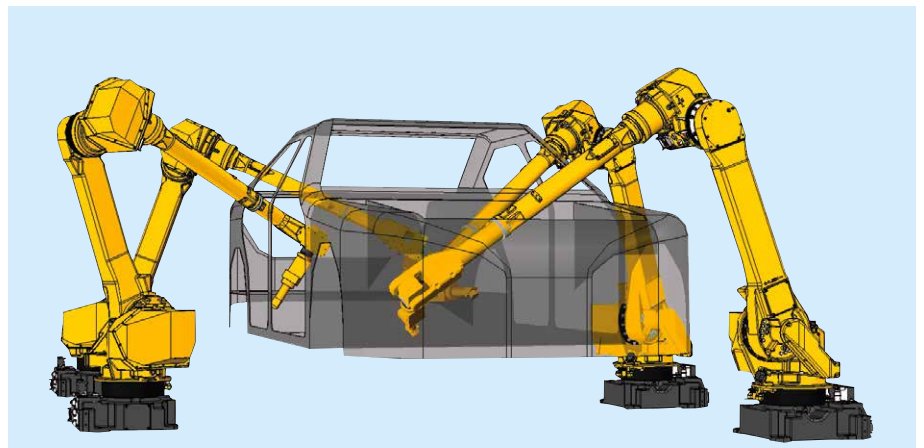

Car Body Sealing

# Operating space

## M-710/50-26D, /70-21D

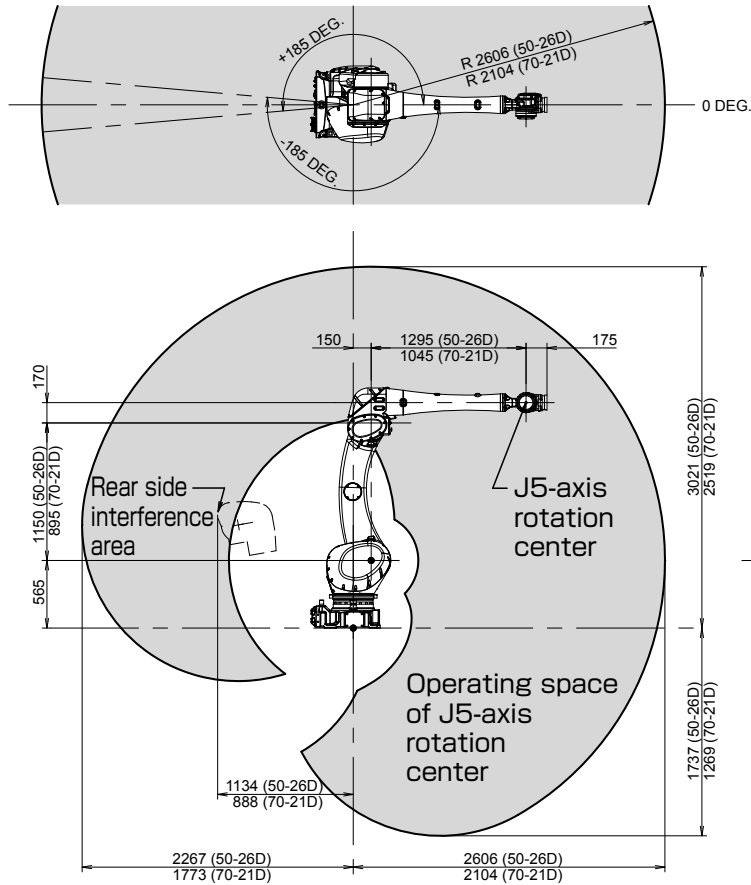

## Specifications

Model		M-710/50-26D	M-710/70-21D
Type		Articulated Type	
Controlled axes		6 axes (J1, J2, J3, J4, J5, J6)	
Reach		2606 mm	2104 mm
Installation (Note 1)		Floor, Upside-down, Angle mount	
Motion range (Maximum speed) (Note 2)	J1 axis rotation	370° (180°/s) 6.46 rad (3.14 rad/s)	370° (180°/s) 6.46 rad (3.14 rad/s)
	J2 axis rotation	225° (180°/s) 3.93 rad (3.14 rad/s)	225° (180°/s) 3.93 rad (3.14 rad/s)
	J3 axis rotation	440° (180°/s) 7.68 rad (3.14 rad/s)	440° (180°/s) 7.68 rad (3.14 rad/s)
	J4 axis wrist rotation	800° (260°/s) 13.96 rad (4.54 rad/s)	720° (260°/s) 12.57 rad (4.54 rad/s)
	J5 axis wrist swing	250° (260°/s) 4.36 rad (4.54 rad/s)	250° (260°/s) 4.36 rad (4.54 rad/s)
	J6 axis wrist rotation	800° (370°/s) 13.96 rad (6.46 rad/s)	720° (370°/s) 12.57 rad (6.46 rad/s)
Max load capacity at wrist		50 kg	70 kg
Max load capacity on J3 casing (Note 3)		Total 20 kg	20 kg
Max load capacity on J3 arm (Note 3)			20 kg
Allowable load moment at wrist	J4 axis	215 N·m 22 kgf·m	300 N·m 31 kgf·m
	J5 axis	215 N·m 22 kgf·m	300 N·m 31 kgf·m
	J6 axis	130 N·m 13 kgf·m	150 N·m 15 kgf·m
Allowable load inertia at wrist	J4 axis	30 kg·m <sup>2</sup> 306 kgf·cm·s <sup>2</sup>	30 kg·m <sup>2</sup> 306 kgf·cm·s <sup>2</sup>
	J5 axis	30 kg·m <sup>2</sup> 306 kgf·cm·s <sup>2</sup>	30 kg·m <sup>2</sup> 306 kgf·cm·s <sup>2</sup>
	J6 axis	20 kg·m <sup>2</sup> 204 kgf·cm·s <sup>2</sup>	15 kg·m <sup>2</sup> 153 kgf·cm·s <sup>2</sup>
Drive method		Electric servo drive by servo motor	
Repeatability (Note 4)		± 0.06 mm	± 0.03 mm
Mass (Note 5)		600 kg	580 kg
Installation environment		Ambient temperature : 0 to 45°C Ambient humidity : Normally 75 %RH or less (No condensation allowed.) Short term (within one month) Max. 95 %RH or less (No condensation allowed.) Vibration acceleration : 4.9m/s <sup>2</sup> (0.5G) or less	

Note 1) In case of angle mounting, J1 and J2 axis motion range are restricted.

Note 2) During short distance motions, the axis speed may not reach the maximum value stated.

Note 3) Max. load capacity on J3 arm and J3 casing are limited by payload at wrist.

Note 4) Compliant with ISO 9283.

Note 5) Without controller.

# Operating space

## M-710/12-31C, /20-31C, /20-26C

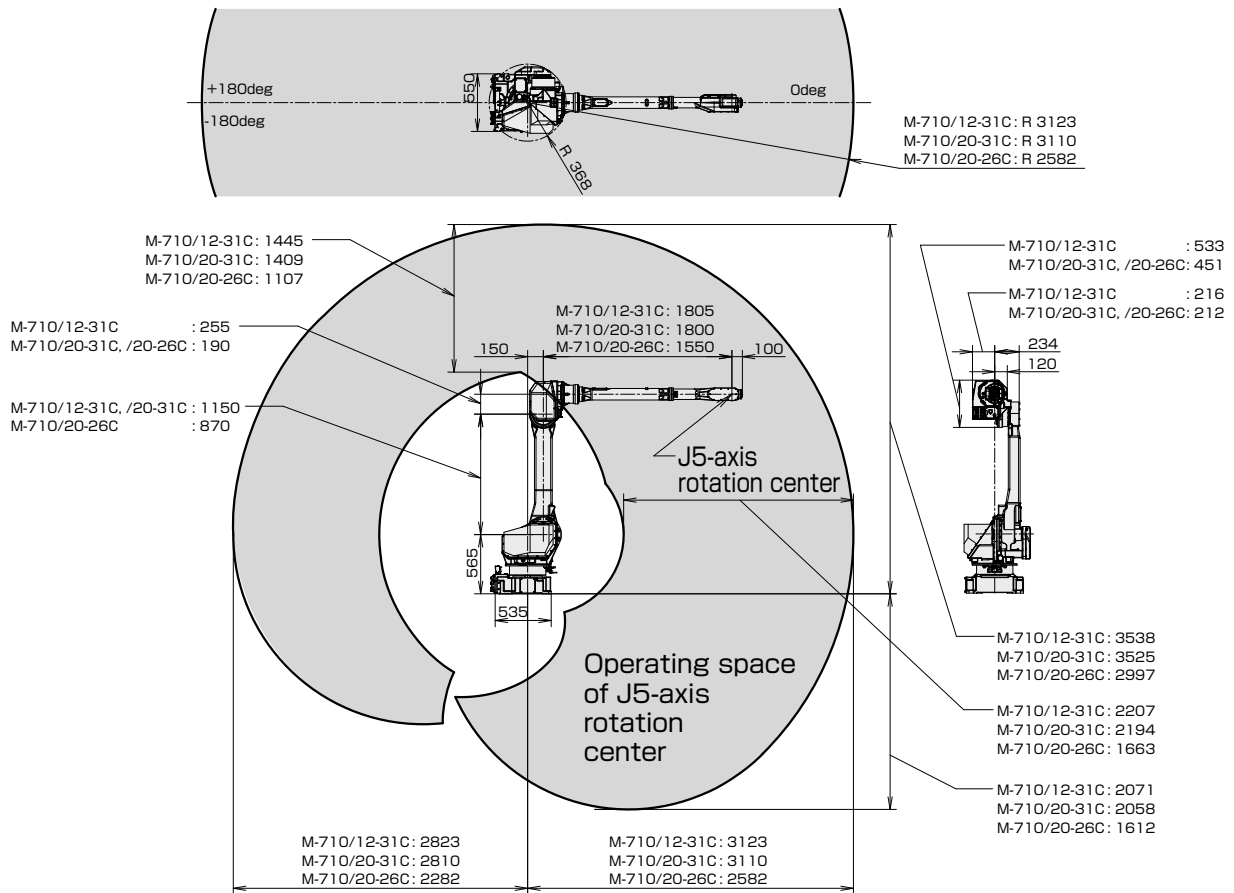

## Specifications

Model		M-710/12-31C	M-710/20-31C	M-710/20-26C
Type		Articulated Type		
Controlled axes		6 axes (J1, J2, J3, J4, J5, J6)		
Reach		3123 mm	3110 mm	2582 mm
Installation (Note 1)		Floor, Upside-down, Angle mount		
Motion range (Maximum speed) (Note 2)	J1 axis rotation	360° (180°/s) 6.28 rad (3.14 rad/s)	360° (175°/s) 6.28 rad (3.05 rad/s)	360° (175°/s) 6.28 rad (3.05 rad/s)
	J2 axis rotation	225° (180°/s) 3.93 rad (3.14 rad/s)	225° (165°/s) 3.93 rad (2.88 rad/s)	225° (175°/s) 3.93 rad (3.05 rad/s)
	J3 axis rotation	434° (180°/s) 7.57 rad (3.14 rad/s)	432° (180°/s) 7.54 rad (3.14 rad/s)	435° (180°/s) 7.59 rad (3.14 rad/s)
	J4 axis wrist rotation	400° (400°/s) 6.98 rad (6.98 rad/s)	400° (350°/s) 6.98 rad (6.11 rad/s)	400° (350°/s) 6.98 rad (6.11 rad/s)
	J5 axis wrist swing	380° (430°/s) 6.63 rad (7.50 rad/s)	280° (360°/s) 4.89 rad (6.28 rad/s)	280° (360°/s) 4.89 rad (6.28 rad/s)
	J6 axis wrist rotation	720° (630°/s) 12.57 rad (11.0 rad/s)	900° (600°/s) 15.71 rad (10.47 rad/s)	900° (600°/s) 15.71 rad (10.47 rad/s)
Max. load capacity at wrist		12 kg		20 kg
Max. Load capacity at J3 casing (Note 3)		24 kg		
Allowable load moment at wrist	J4 axis	22.0 N·m 2.24 kgf·m	39.2 N·m 4.0 kgf·m	
	J5 axis	22.0 N·m 2.24 kgf·m	39.2 N·m 4.0 kgf·m	
	J6 axis	9.8 N·m 1.0 kgf·m	19.6 N·m 2.0 kgf·m	
Allowable load inertia at wrist	J4 axis	0.65 kg·m <sup>2</sup> 6.6 kgf·cm·s <sup>2</sup>	0.88 kg·m <sup>2</sup> 9.0 kgf·cm·s <sup>2</sup>	
	J5 axis	0.65 kg·m <sup>2</sup> 6.6 kgf·cm·s <sup>2</sup>	0.88 kg·m <sup>2</sup> 9.0 kgf·cm·s <sup>2</sup>	
	J6 axis	0.17 kg·m <sup>2</sup> 1.7 kgf·cm·s <sup>2</sup>	0.25 kg·m <sup>2</sup> 2.6 kgf·cm·s <sup>2</sup>	
Drive method		Electric servo drive by servo motor		
Repeatability (Note 4)		± 0.06 mm		
Mass (Note 5)		540 kg		530 kg
Installation environment		Ambient temperature : 0 to 45°C Ambient humidity : Normally 75 %RH or less (No condensation allowed.) Short term (within one month) Max. 95 %RH or less (No condensation allowed.) Vibration acceleration : 4.9m/s <sup>2</sup> (0.5G) or less		

Note 1) In case of the angle mounting, the J1 and J2 axis motion range are restricted.

Note 2) During short distance motions, the axis speed may not reach the maximum value stated.

Note 3) Max. load capacity at J3 casing is limited by payload at wrist.

Note 4) Compliant with ISO 9283.

Note 5) Without controller.

# Operating space

## M-710/50-20C-5X

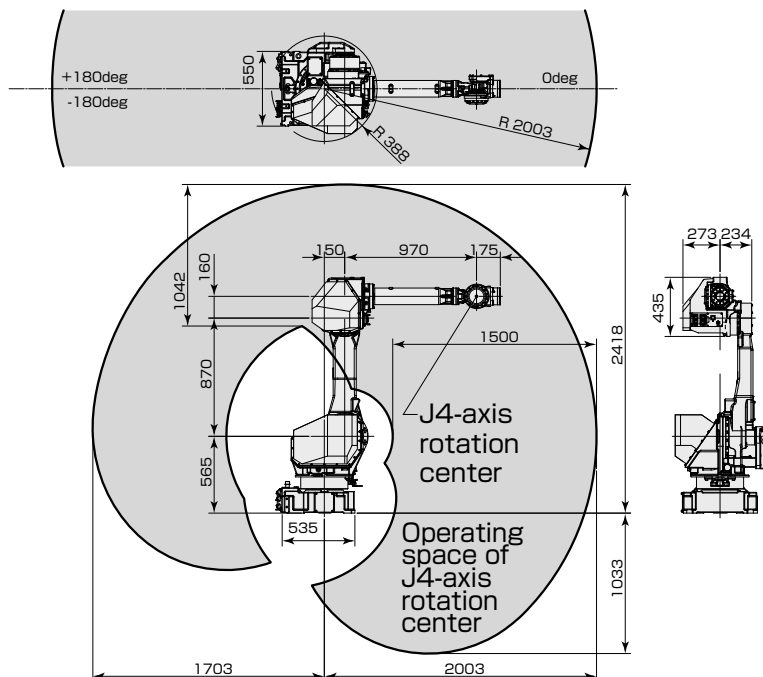

## Specifications

Model		M-710/50-20C-5X
Type		Articulated Type
Controlled axes		5 axes (J1, J2, J3, J4, J5)
Reach		2003 mm
Installation		Floor, Upside-down
Motion range (Maximum speed) (Note 1)	J1 axis rotation	360° (1.75°/s) 6.28 rad (3.05 rad/s)
	J2 axis rotation	225° (1.75°/s) 3.93 rad (3.05 rad/s)
	J3 axis rotation	440° (1.75°/s) 7.68 rad (3.05 rad/s)
	J4 axis wrist swing	234° (1.75°/s) 4.08 rad (3.05 rad/s)
	J5 axis wrist rotation	720° (7.20°/s) 12.57 rad (12.57 rad/s)
Max. load capacity at wrist		50 kg
Max. load capacity at J3 casing (Note 2)		15 kg
Allowable load moment at wrist	J4 axis	150 N·m 15.3 kgf·m
	J5 axis	68 N·m 6.9 kgf·m
Allowable load inertia at wrist	J4 axis	6.3 kg·m <sup>2</sup> 64.3 kgf·cm·s <sup>2</sup>
	J5 axis	2.5 kg·m <sup>2</sup> 25.5 kgf·cm·s <sup>2</sup>
Drive method		Electric servo drive by servo motor
Repeatability (Note 3)		± 0.03 mm
Mass (Note 4)		540 kg
Installation environment		Ambient temperature : 0 to 45°C Ambient humidity : Normally 75 %RH or less (No condensation allowed.) Short term (within one month) Max. 95 %RH or less (No condensation allowed.) Vibration acceleration : 4.9m/s <sup>2</sup> (0.5G) or less

Note 1) During short distance motions, the axis speed may not reach the maximum value stated.

Note 2) Max. load capacity at J3 casing is limited by payload at wrist.

Note 3) Compliant with ISO 9283.

Note 4) Without controller.

# FANUC CORPORATION

● Overseas Affiliated Companies  
 FANUC America Corporation  
 FANUC Europe Corporation, S.A.  
 SHANGHAI-FANUC Robotics CO., LTD.  
 KOREA FANUC CORPORATION  
 TAIWAN FANUC CORPORATION  
 FANUC INDIA PRIVATE LIMITED  
 FANUC SINGAPORE PTE. LTD.  
 FANUC THAI LIMITED  
 FANUC MECHATRONICS (MALAYSIA) SDN. BHD.  
 PT. FANUC INDONESIA  
 FANUC OCEANIA PTY. LIMITED  
 FANUC SOUTH AFRICA (PROPRIETARY) LIMITED

Phone: (+1)248-377-7000  
 Phone: (+352)727777-1  
 Phone: (+86)21-5032-7700  
 Phone: (+82)55-278-1200  
 Phone: (+886)4-2359-0522  
 Phone: (+91)80-2852-0057  
 Phone: (+65)6567-8566  
 Phone: (+66)2-714-6111  
 Phone: (+60)3-3082-1222  
 Phone: (+62)21-4584-7285  
 Phone: (+61)2-8822-4600  
 Phone: (+27)11-392-3610

● Headquarters 3580, Shibokusa, Oshino-mura, Minamitsuru-gun  
 Yamanashi, 401-0597, JAPAN  
 Phone: (+81)555-84-5555 <https://www.fanuc.co.jp/>

<https://www.fanucamerica.com/>  
<https://www.fanuc.eu/>  
<https://www.shanghai-fanuc.com.cn/>  
<https://www.fkc.co.kr/>  
<https://www.fanuctaiwan.com.tw/>  
<https://www.fanucindia.com/>  
<https://www.fanuc.com/fsp/>  
<https://www.fanuc.com/ftth/>  
<https://www.fanuc.com/fmm/>  
<https://www.fanuc.com/fin/>  
<https://www.fanucoceania.com.au/>  
<https://fanuc.co.za/>

● All specifications are subject to change without notice.  
 ● No part of this catalog may be reproduced in any form.  
 ● The products in this catalog are controlled based on Japan's "Foreign Exchange and Foreign Trade Law". The export from Japan may be subject to an export license by the government of Japan. Further, re-export to another country may be subject to the license of the government of the country from where the product is re-exported. Furthermore, the product may also be controlled by re-export regulations of the United States government. Should you wish to export or re-export these products, please contact FANUC for advice.